

PERSONAL AIR VEHICLES: A RURAL/ REGIONAL AND INTRA-URBAN ON-DEMAND TRANSPORTATION SYSTEM

Mark D. Moore[†]
NASA Langley Research Center
Hampton, VA 23681-2199



ABSTRACT

NASA's Aeronautics Blueprint¹ outlines diverse future aviation mobility solutions for travel, expanding upon the single market focus that exists today of a centralized airline hub and spoke system. Certainly the hub and spoke system will continue to be a vital asset for long distance travel, with continued NASA investment in efficiency and environmental technologies. However, the current hub and spoke system doesn't serve rural, regional, and intra-urban travel well for travel distances less than 500 miles², and consumers still choose to use automobiles 20x more often for trip distances of 100 to 500 miles. Automobiles capture 76% of all trips greater than 100 miles, and airlines only 19% with an average auto speed of only 35 mph³; an indicator that there is opportunity for greater mobility in the future. Personal Air Vehicles offer the potential for a breakthrough in mobility, capacity, congestion, and quality of life through the development of an on-demand aerial transportation system. The constraints that currently bound personal transportation could be pushed back to provide opportunities for significant economic growth and improved productivity^{4,5,6,7}. However, there are good reasons why Personal Air Vehicles are currently limited to General Aviation hobbyists, and are not part of a viable transportation system embraced by the public. Significant technology challenges prevent the free market from capitalizing on large market demand and public interest. In a combined effort NASA and industry have identified the missions most applicable to these vehicles and the technology challenges that exist

to lay the foundation for viable products and a vibrant market. A 3-year system study has investigated these missions and technologies, and developed concepts as a framework for understanding the benefits and technology impact. The missions include an evolution from the current small airport operations, to a requirement set that encompass extremely short and vertical takeoff operations. The technology challenges that must be surmounted to support rural and regional missions include ease of use, automated airspace control, affordable propulsion, economically viable concepts, low community noise, modern certification procedures, and near all weather capability while achieving a factor of ten improvement in small aircraft safety. Intra-urban mission technologies that are required include improved propulsion system thrust to weight, increased efficiency, simple yet effective high-lift systems with low-speed control, powered-lift innovations, lightweight structures, design tools capable of the modeling and analysis of unconventional concepts, and the ability to convert alternative energy sources to thrust. Key demonstrations are identified that will establish a clear future vision of vehicle capabilities for a change in perception that encourages investment from the aerospace and auto industries. The objective of this research is to enable safe, affordable, easy-to-use, and acceptable personal air vehicle technologies that expand access to more communities. In addition, much greater reach, flexibility, robustness, freedom, individual control, and speed would be achieved than the current hub and spoke or highway systems for a broad segment of the American public.

[†]Senior Research Engineer, Member

INTRODUCTION

Personal Air Vehicles (PAVs) are envisioned as the next logical step in the natural progression in the nation’s history of disruptive transportation system innovations. As the automobile improved quality of life and standards of living in the 20th century^{8,9,10}, PAVs are envisioned to do likewise in the 21st century. PAVs are defined as self-operated aircraft, capable of use and affordable by a large portion of the general public. The goal of these vehicles is to provide a breakthrough in personal air mobility, through dramatic time-savings and increased reach, and therefore a greatly improved quality of life. There are two key questions involving the future of PAVs; first, is there a significant potential benefit developing such a capability, and second, is such a transportation system affordable and technically possible. An understanding of the current state of mobility is required prior to proposing any improvements, or understanding comparative benefits between systems.

CURRENT STATE OF MOBILITY

Mobility studies¹¹ have shown that over the last 100 years, while travel speeds have increased ten-fold, the average amount of time traveled per day has remained relatively constant at about 1.25 hours per day (Figure 1). This statistic also holds true for other countries at different effective technology levels¹². Over the last 30 years average ground speed has increased slightly to the current value of 35 miles/hour, with 1995 and 2000 data showing the first decreases for ground mobility in many of the productive regions of the country³. Therefore the daily radius of action (or reach) has improved from about 3 miles per day in 1900, to about 25 miles per day (each way) in 2000 for intra-urban travel⁸.

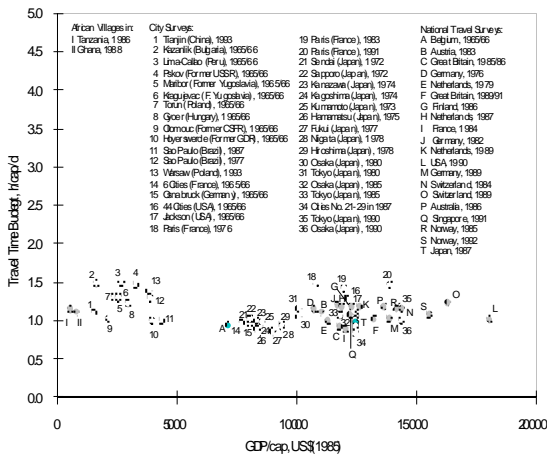

Figure 1. Time Spent on Travel

U.S. travel trends appear to substantiate that personal mobility demand will soar beyond supply in the early portion of the 21st century³ (Figure 2). As ground

highway and air hub and spoke travel congestion result in increasing delays, the infrastructure investment required to attempt breakeven through these two highly constrained systems will be insufficient and artificially limit economic growth through loss of time and opportunity. For instance, the average highway speed in the L.A. area is projected to decrease from 33 mph to less than 22 mph over the next 20 years⁴.

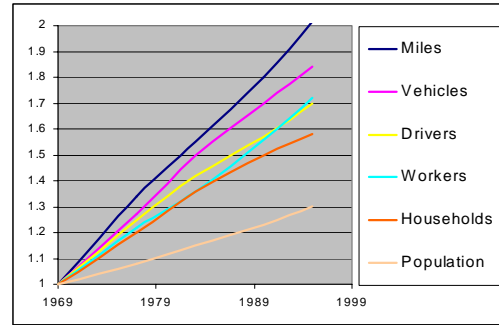

Figure 2. Personal Travel Trends in the U.S.³ (Relative to 1969)

While airlines provide a vital mobility service, they don’t comprise a significant share of the total market. Approximately 50% of all travel trip-miles involve distances less than 25 miles³ (accounting for over 90% of all trips), and clearly these trips will belong to the auto mode of travel for many years to come. Another 40% of the trip-miles are at distances from 25 to 100 miles, with autos currently capturing almost 100% of that market. The remaining 10% of trip-miles are at distances greater than 100 miles, with autos capturing 76% of that market and airlines only 19% (Figure 3). Therefore airlines only account for about 2% of all trip-miles, and a much lower percentage of all trips. Clearly with this small fraction of travel market share, aviation could be perceived as less important if investment is driven by the ability to impact daily quality of life.

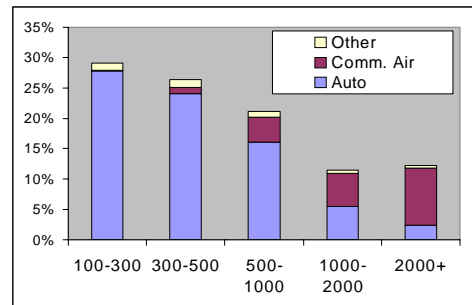

Figure 3. Current Mode Choice Based on Distance³ (Trips greater than 100 miles)

Utilizing current high-speed transportation (commercial airlines) does not yield an improvement in block speed over ground travel at the ranges where the bulk of trips

are taken^{13,14,15}. This is likely one reason why autos are chosen as the travel mode more than twenty times more often than airlines for distances from 100 to 500 miles. Obviously there is a key difference between airlines, which operate in a centralized hub and spoke infrastructure, and autos or future PAVs, which operate in a highly distributed infrastructure and offer closer proximity to destinations and a significantly less burden than centralized services (driving many miles to reach a hub, arriving early for ticketing, security, baggage checks, connections through other hubs, etc). A current study being conducted by Volpe in cooperation with NASA shows that 29% of the total door-to-door trip time is the actual gate-to-gate time of the airliner for trips under 500 miles.

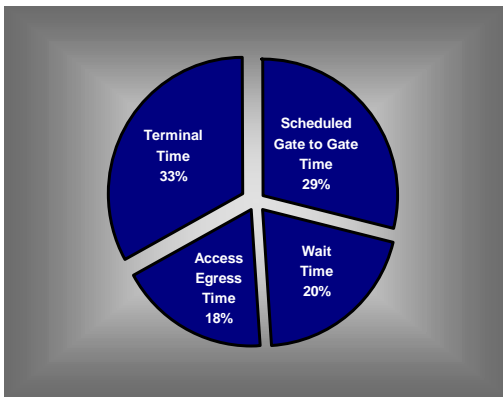

Figure 4. Volpe Commercial Airline Door-to-Door Trip Time Breakdown (<500 mile range)

Rural and regional travel suffers from an additional mobility limitation of lack of service. A recent GAO report² found that these communities are burdened with an incomplete transportation system that can severely limit the economic prospects of future development. These communities are already dependent on General Aviation (GA), and are therefore likely first adopters of a PAV transportation system.

“Small communities face a range of fundamental economic challenges in obtaining and retaining commercial passenger air service. The smallest of these communities typically lack the population base and level of economic activity that would generate sufficient passenger demand to make them profitable to air carriers.”²

The civil aviation system has experienced relatively steady growth for 50 years¹⁶, along a steady maturation of the hub and spoke system. The hub and spoke system (Figure 6) is incredibly efficient in terms of aircraft utilization and costs, however it is a highly centralized system with over 90% of all air travel going through 30 airports¹⁷. In terms of door-to-door passenger time, comfort, convenience and satisfaction,

the hub and spoke system is extremely ineffective. All systems evolve, based on a combination of slow growth and catastrophic events. Understanding the driving evolutionary forces permits an understanding of the pressures and where they may lead. The driving factors that will shape the future aviation system are the ability for manufacturers and airline operators to make a profit, the need to travel, capacity throughput, environmental impacts, safety, reliability, and consumer preference.

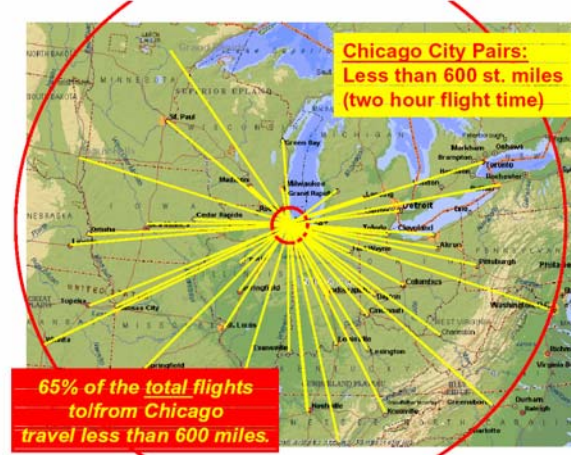

Figure 5. Example of Current Hub and Spoke System

Aviation is currently going through one such catastrophic event due to the terrorist attacks of September 11th, which raises an important issue. The hub and spoke aviation system can only continue to grow if it is a robust system. Currently, with a weather delay at just one of the major hubs, the entire system experiences significant setbacks. If ground to air missiles attacks on airliners were to occur in the U.S., there is very little that could be done to keep large aircraft secure in the skies. Current proposals include spending \$10 billion on equipping every airline with tail mounted infra-red dazzler technology, which will not solve the future vulnerability of large, unmaneuverable transports from newer multi-spectral infra-red missiles, or simple non-tracking projectile weaponry. No matter what attempts are made at securing the safety of large transports, they will continue to make highly visible and tempting targets. While centralized systems are efficient, they do not provide a robust system solution. In nature, natural selection shows that for systems to survive and promote the maximum market size, highly distributed systems result. This robustness is essential to prevent a catastrophic loss in mobility that would yield disastrous effects on the economy.

FUTURE POTENTIAL STATE OF MOBILITY

Considering the true door-to-door block time, on-demand PAVs have the potential to achieve a daily

mobility reach of 125 to 250 miles, providing another five to ten fold increase over the auto today. Imagine the last 100 years without the ten-fold increase provided by the auto over the horse, and the constraining effect this would have had on the economy. A similar fate awaits us over the next 100 years unless mobility solutions yielding revolutionary improvements are investigated. If the statistical travel data continues the same 100-year trend, it appears that once high-speed, on-demand travel service is offered to the market, consumers will utilize these vehicles for increased mobility reach instead of saving travel time¹¹. This is an important consideration since PAVs will compete with alternative vehicle modes, and PAV acquisition cost is inherently more expensive than autos. Deferring the higher acquisition cost over an equivalent vehicle utilization (instead of ¼ due to the block speed advantage) is critical to achieve high levels of affordability. Consumer behavior supports this model; once a fixed vehicle cost is paid, additional travel only requires recurring costs, which are often small. If PAVs can achieve high levels of affordability, there is the opportunity to impact society as dramatically as the transition from the horse and buggy era, allowing a similar expansion to underutilized resources (currently the U.S. utilizes approximately 5% of the land mass for population support¹⁷).

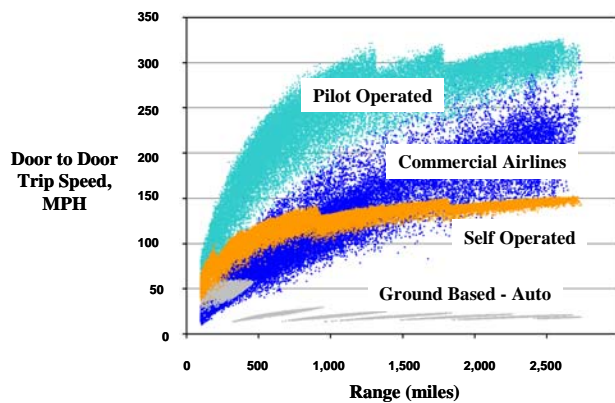

Figure 6. Block Speeds of Various Travel Choices

A recent study conducted by TeamVision¹⁷ analyzed a high number of trips comparing four different transportation modes to perform the same trip. Each trip was from county center to county center of every county in the U.S. to represent trip samples. Actual ground time was determined by using web-based ground travel estimators for every individual trip. Actual airline flight times were used for commercial airline gate-to-gate time, also using a web-based querying system. Airlines and autos were compared to a self-operated 180 mph PAV, and a 360 mph on-demand air-taxi, with burden times before and after flights (averaging 2.75 hrs intermodal ground time for hub and

spoke airlines, 1.25 hrs for on-demand air travel, and zero for autos). The on-demand burden times are significantly less than in a distributed system than a centralized system, balancing the greater cruise speeds of the airlines. On average, the door-to-door speed of airlines is about 80 miles/hr on trips less than 500 miles, and decreases to about 50 miles/hr for trips less than 250 miles (Figure 4). It is important to recognize that this study does not assume any new airport locations, other than those currently available. However the study does assume a critical mass of operations has been achieved, and therefore rental car companies support small airports. Additionally an assumption has been made that both the self-operator and air-taxi aircraft are equipped with advanced electronic checklists that reduce current ground start-up times, and a SATS-like Highway In The Skies air traffic is in place to reduce trafficking schedule delays.

Scheduled services add additional time inefficiencies over on-demand service that aren't captured in this block speed comparison due to the traveler having to adapt his schedule to the airline's schedule (you may want to depart hours earlier but that option is not available and therefore that time is wasted). Time loss due to missing a flight or connection is also not captured in these averaged time burdens. In addition, travelers are required to build-in time allowances to account for the standard deviation of arrival times in order to arrive at any given location on-time. The mean deviation for centralized carriers is significantly higher than on-demand service (ie the amount of scatter in Figure 6), requiring a longer allowance to ensure travel can be completed within a specified timeframe. These time factors dramatically reduce the effective block speed and play a more important determiner of why the majority of consumers will choose on-demand services over centralized. On-demand travel permits the traveler to maintain control over the travel process. These reasons are a partial explanation of why travelers choose on-demand service as often as scheduled service for travel distances of even 2000 miles (Figure 3), even though large time burdens are associated with long distance auto travel.

A web-based benefits tool was developed by Georgia Tech Aerospace Design Lab¹³ to assist in the visualization of the potential benefit of PAVs. This tool permits users to select from a wide range of PAV types to compare the total door-to-door block speed of various transportation systems. PAV models include CTOL, ESTOL, VTOL and Dual-use vehicles (ie aircraft that can travel on roadways to some degree) with low or high speed cruise capability across these vehicle groups. In addition the user can perform sensitivities on the time burden assumptions associated

with mode changes (i.e. ground to air travel modes) to establish their own level of credibility for the potential timesaving, or increased reach that is achievable with an on-demand transportation system. Economic models are also present¹⁴ to cost compare different modes of travel while customizing the user trip profiles to determine which vehicle type is optimum for a given traveler profile.

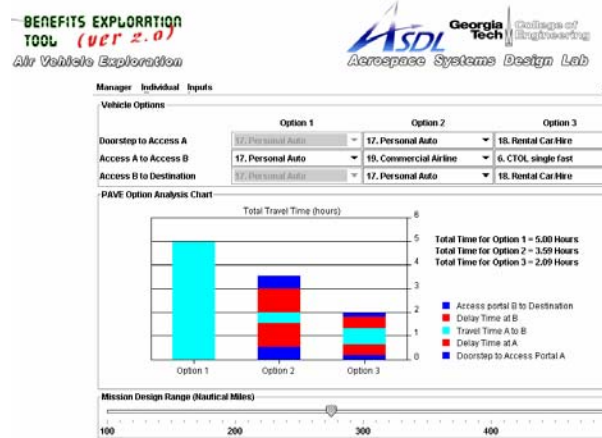

Figure 7. PAV Web Based Benefits Exploration Tool (<http://www.asdl.gatech.edu/teams/pave>)

The prior discussion has outlined the potential for significant improvements in mobility for both the rural/regional and intra-urban markets. The question does not appear to be whether radical improvements in mobility would promote dramatic improvements in economic opportunity and quality of life. Instead the key question appears to be whether a distributed, on-demand transportation system utilizing personal air vehicles is affordable, and technically feasible.

PAV MARKET AND AFFORDABILITY

The future affordability of PAVs is in large part dependent on understanding the future market size of trips captured by this mode of transportation, as it competes with autos and airlines. Market size will determine production volumes, the level of integration into other transportation modes, infrastructure support costs, and the ability for the infrastructure to accommodate the predicted travel volumes. Each of these factors plays into the acquisition and operating costs, and thus the affordability of the system.

While the small aircraft industry has conducted market studies to predict the future sales, the resulting predictions are only of value as general trends. Performing these type of extrapolations when new factors dramatically change the market will not provide useful predictions. These prediction methods use parameters such as inflation, number of student pilots,

aircraft resale prices, discretionary income, and number of operations to extrapolate into future years. Currently, approximately 1000 single engine aircraft are sold per year¹⁸, while over the last 50 years an average of 6500 aircraft were sold per year¹⁹. The cumulative sales demonstrate an almost perfect S curve behavior of a fully mature product market²⁰.

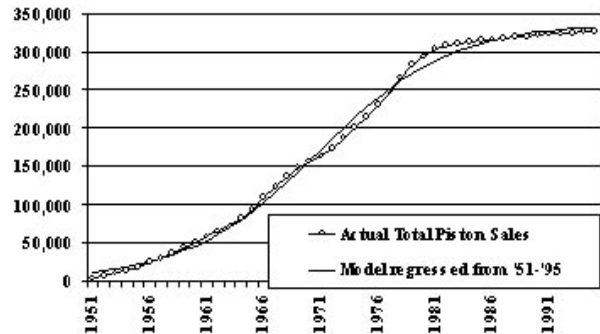

Figure 8. Single Engine Aircraft Sales (1961 – 2001)

Normalized income data provides a useful measure of both discretionary income and the value of personal time. Income trends over the past 40 years demonstrate that the top 5% and 20% income brackets have achieved more substantial increases than the average income, with the respective incomes increasing 97%, 73%, and 30% over the last 40 years (Figure 9)²¹. The associated value of time forms the core bias as auto, airline, and on-demand air travel compete with each other to determine the resulting market share.

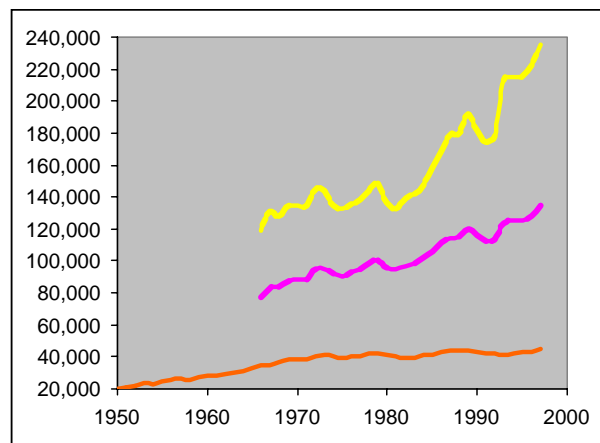

Figure 9. U.S. Income for Top 5%, 20%, Average (Excluding capital gains, 1997 constant year dollars)

A mode choice market demand model was recently developed by Dollyhigh¹⁵ that provides a more robust method of predicting future demand, even in the presence of radical market change or innovation. The analysis method estimates the pool of potential users of small aircraft by developing a model for all auto and

airline trips. This model is built upon known airline operations (both commercial and private), the American Travel Survey, and the latest census. The combined dataset and tool is the Integrated Air Transportation System Evaluation Tool (IATSET), that predicts at a national level the mode choice distribution based on the value of each traveler's time and the monetary cost of the trip. Person trips are determined as a function of distance traveled and income, with the lowest total cost mode being selected as the mode choice. Each mode of transportation consists of a trip fixed cost (per trip) and a variable cost (per mile).

Initial analysis using this model accurately predicts that the market for a Cirrus SR-20 'like' aircraft does not capture any new person trips as it competes with autos and airlines at a trip rate of 100 flights per year. This utilization is similar to current personal average usage, with the results indicating that current sales are not based on a logical choice for transportation, but by hobbyist (the other modes of travel win the time-cost competition). However, once the aircraft price was dropped to an \$80,000 acquisition cost model, the aircraft was able to capture 6 million person trips at 100 flights per year, or 48 million person trips at 400 flights per year (equating to 200 trips per year or commuting to work by air). The result of capturing this many trips by this mode of transportation translates to an increase in the current GA market of 25% from the current active fleet of about 225,000 units. This analysis assumes there is a sufficient pilot base, or that ease of use technology has been implemented to ease training cost and time to an equivalent level as autos, and that the small aircraft is capable of achieving a near all weather flight capability in a modern airspace environment.

New analysis was performed by Dollyhigh to determine the sensitivity of the total trip market to the fixed and variable costs (Figures 10-12). In addition, initial studies showed a very high sensitivity to speed, with a loss of over 40% of the person trips as the cruise speed dropped from 162 mph to 140 mph. The new analysis would permit performance and cost characteristics of a NASA developed highly affordable small aircraft concept to be compared to the prior Cirrus based model. The travel mode choice criteria was based on an auto cost model of zero trip cost plus \$.34 per mile variable cost, and no intermodal time burden. The airline cost model was a \$58.43 fixed trip cost plus \$.0561 per mile variable cost, and a 2.75 hr time burden for door-to-door transit. The small aircraft was analyzed at several cost structures with a 1.25 hr time burden for door-to-door transit. The baseline NASA highly affordable model is a 5 place, non-pressurized, 200 mph cruise, 500 mile range, near all weather vehicle designed to achieve dramatic cost and noise reductions. It has a

predicted price of \$75,000 in production volumes of 2,000 units per year, which translates to a fixed cost of about \$50 per flight and \$.30 per mile variable cost at approximately 200 flights per year utilization. Achieving this cost goal and utilization would result in greater than a 100% increase in the size of the GA market in the current market year. Annualized costs would be approximately \$25,000 for 250 hours, and a total operating cost on the order of \$.50 per mile. This compares to a 25 year-old Cessna 182 that has a fixed cost of approximately \$34,000 per year currently for the same hours, or \$1.00 per mile (with the Cessna being 40 mph slower).

While these mode choice market analyses raise many questions on the validity of the assumptions, it is proving to be a valuable tool to demonstrate the sensitivity of the market demand to mission, concept, and technology assumptions. This demand analysis shows that it is critical to achieve dramatic cost reductions to achieve a significant mobility impact. The methods of achieving the cost goal of the prior analysis will be discussed in the mission concepts section of this paper. However, with the market demand predicted, production volumes would greatly exceed the current number of 1000 per year, or the assumed production volume of 2000 per year, with the typical cost learning curve decreasing unit cost by 10% for each doubling of production. If the cost goals were achieved, it is likely that many of the current GA fleet would be replaced, since the current average GA vehicle age is 35 years old, yielding additional sales.

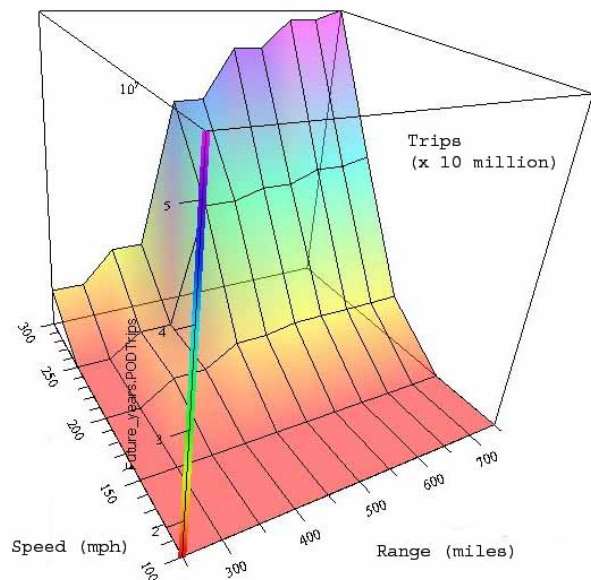

Figure 10. PAV Mode Choice Trip Demand (\$100 fixed flight cost, \$.50/mile cost, equivalent to 100 flights per year utilization)

The assumed utilization translates to the top 20% of current travelers, but is also achievable using non-aggressive partial ownership and air rental ownership models. In fact it is likely that either of these operation models could result in 400 to 1200 flights per year. Based on the prior discussion of high-speed mobility adopters choosing increased reach over timesaving, it is likely that the average utilization of PAVs will increase from today's value of 125 flights per year. Once a fixed vehicle cost is incurred, it is likely that the owner will choose increased usage at the variable cost rate. For all of these analyses, the load factor was assumed to be the census averaged 3.2 passengers at the income support level of the trip, though the aircraft is capable of 5 passengers. In addition the range was limited to its' full design load range of 500 miles, though obviously with a partial payload increased range capability results. It can still clearly be seen that there is a high sensitivity to speed, with a cruise speed of at least 200 mph required to capture significant trips.

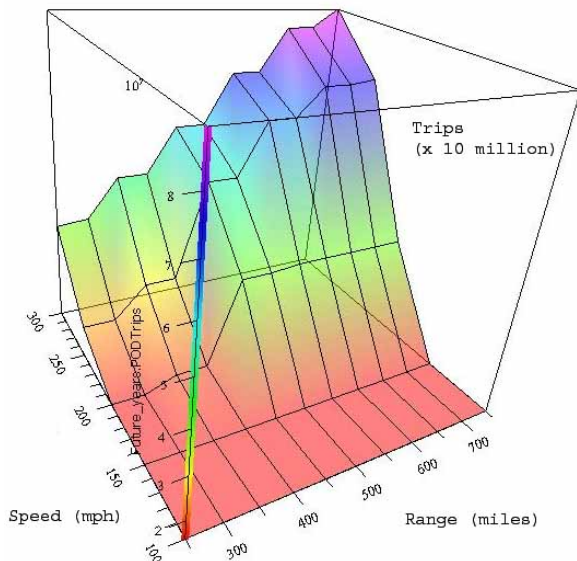

Figure 11. PAV Mode Choice Trip Demand (\$50 fixed flight cost, \$.50 /mile cost, equivalent to ~200 flights per year utilization)

The projected market demand model does not take into account any additional latent market that would exist once this new high-speed, on-demand mobility travel is made available. Certainly there would be additional market growth and opportunity, and not just a redistribution of the current market as new services were offered. In addition, this model has currently only considered personal travel, although both business and personal travel can be analyzed within the model. More trip demand potential exists once business and government service travel is included. This analysis

has only attempted to estimate the near-term market that could exist if next generation GA type PAVs provide competitive mid-range transportation that can offload auto and airline travel. This model will also be used to examine the far-term market that involves vehicles that are Extreme Short Takeoff and Landing (ESTOL) and Vertical Takeoff and Landing (VTOL) capable. The market projections are based an extrapolation of the census, travel survey and airline trips and follow the past 25 year growth patterns. Again, this analysis will be conservative since it does not account for new market demand that high-speed mobility will empower. Similar analyses are currently being conducted with mid-term and long-term assumption sets to understand the potential market yield, and the required levels of affordability.

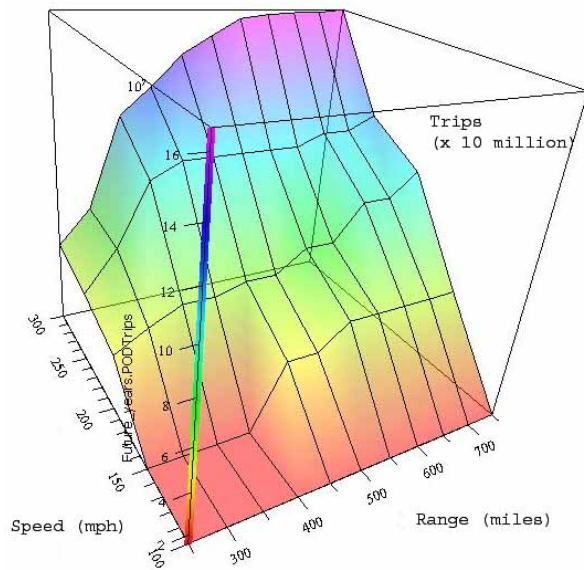

Figure 12. PAV Mode Choice Trip Demand (\$100 fixed flight cost, \$.25 /mile cost, equivalent to ~100 flights per year utilization)

While these travel trends and market predictions assist in understanding the impetus for a goal such as PAVs, a more powerful illustration of the potential impact can be found in other on-demand markets that have demonstrated radical growth over the last 20 years. The personal computer, PDA, cell phone, email, fax, and internet have created on-demand, distributed services that are replacing the centralized services of mainframe computing, land phone lines, postal mail, and bricks and mortar merchants. Associated with these highly distributed, on-demand computing, communication and commerce is a substantial improvement in productivity that empowers an improved quality of life, and the ability for a large portion of the public to afford these products, though each was once an expensive frivolity that would only pertain to a limited and exclusive market.

NASA'S ROLE

The vision of providing on-demand personal air mobility is tightly aligned with NASA's Aeronautical Research Theme of enhancing mobility, and providing faster, further travel, anywhere, at anytime. NASA's aeronautics blueprint defines the areas of responsibility of increasing national security, improving quality of life, and expanding economic growth. A robust aviation system, providing increased daily mobility, and a new growth market for industry products meets these goals. The key discriminator to determine if NASA should be involved is whether there is a substantial public benefit, and if NASA is the only entity capable of bringing about this benefit. The most telling answer to this question is the fact that with the many 25 year plans that exist across federal and local government planning, the focus is on trying to maintain current mobility, not provide a radical improvement. There is no other way to achieve this dramatic of a mobility reach, and in many respects this is a John F. Kennedy like challenge. Fortunately the scale of the vehicles, and program costs are much more manageable, though the impact of success would be as dramatic.

NASA has already made investments in small aircraft through AGATE (Advanced General Aviation Transportation Experiments), GAP (General Aviation Propulsion), and SATS (Small Aircraft Transportation System)¹⁷. Combined, these programs have established advanced cockpit systems, crashworthiness and lightning strike standards, an advanced small turbofan engine, automatic takeoff and landing vehicle control, prototype efforts for a Highway in the Sky airspace control system, and many other elements of the total required system.

Whatever the future will be in civilian aviation, the government will play a significant role by stimulating research in high payoff technologies and by imposing societal constraints. Government research shifts industry focus from near-term profit, to a longer-term vision. At the same time constraints are imposed on industry to provide limits on an otherwise profit driven focus to insure safety and environmental friendliness. A key question is whether the government will continue to have a dominant role in shaping the future of aviation. NASA is the primary government agency for creating future aviation technologies, with a charter to invest in America's future and to do what private industry can't. The FAA manages the national aviation transportation system, insuring operational safety through aircraft certification, regulations and airspace control. Partnerships between these two agencies, and industry are required to bring this PAV vision to fruition, as the interdependency of the technology

challenges are confronted. These partnerships present the opportunity to leap hurdles that would otherwise relegate us to continuing a slow evolutionary crawl in aviation. If the airspace is not dramatically improved from managing a hand-full of aircraft at a time, and long-term research in advanced vehicle technologies is not performed, it is unlikely that industry will break through the current entrenched solutions.

An on-demand aviation system, with self-operated small aircraft that are as easy to fly, comfortable, affordable, environmentally friendly, safe, reliable, and as quiet as driving a car. has been a future vision shared by the Wright Brothers, Henry Ford, and many dreamers along the path of aviation. But solutions have only been attempted in a piecemeal fashion by pioneers out of the equivalent of their own garages for the past 50 years. Clearly, establishing a new transportation value network, as well as many of the technologies for the vehicles that would operate in them, is beyond the means of entrepreneurs, pioneers, and even the established aerospace industry.

While PAVs embrace a bold vision for the future that could affect society at every level, many will question the feasibility of such a system. Yet when compared to other challenges, the technology hurdles are less severe and the benefits are much greater in terms of every day impact to quality of life. Supersonic or hypersonic travel must find technology solutions that provide significant increases in efficiency while achieving dramatic reductions in noise and sonic boom in order to be feasible, and even then will only impact long distance travel, which is a small fraction of the total travel market. Clearly long-term research is required by NASA to develop a future supersonic travel capability, however, as NASA invests in the future of aviation, this investment choice should be driven by the potential benefit to the American public. PAVs have the potential to impact up to 45% of trip-miles traveled, while a supersonic transport has the potential to impact less than 5%. High-speed trains are another method of increasing mobility, but only along established high population corridors, and not within NASA's responsibility. Increasing daily reach, while providing the security of a distributed travel system is a core value network that would daily impact the American public.

MISSION CONCEPTS

Achieving focused research objectives requires that there is a clear understanding of the vehicle class being proposed, as well as the concept of operations. PAVs would operate in the near-term from the current base of 5300+ public and 5000+ private general aviation airports¹⁷. Many more airfields are in use than people

suspect, with a recent survey of operations showing over 18,000 airfields in use¹⁵. This number excludes the nearly 10,000 additional heliports that are available, with many of these locations coincident to hospitals. PAVs would not operate out of the busiest 100 public airports, which comprises the hub and spoke system. Essentially, the infrastructure already exists today to support a distributed PAV transportation system, at least in terms of land use. Typically one of the largest hurdles in developing a radical improvement in society is the development of the new infrastructure. In the case of PAVs, the infrastructure is essentially already in place, and is simply a drastically underutilized resource.

However, the availability of existing infrastructure raises a critical issue in terms of the window of opportunity for when a PAV transportation system could be operational. One argument would be to wait until the current ground and air systems reach a level of service that requires market forces to demand a new solution. This is not realistic for two reasons. First, establishing the changes required in the airspace system will almost certainly take over 20 years, just as it took local governments 20 years from the introduction of the automobile to provide sufficient infrastructure for autos to be considered useful. Certainly local governments are not going to build the air highways, and federal implementation of a national system is required. There is the need to plan at least 20 years ahead, which puts the U.S. squarely up against the wall of 20-year congestion projections that appear unmanageable for many of the most productive regions of the country. The second reason for near-term development of an on-demand transportation system is that the required infrastructure is disappearing at a rapid rate. Currently small, public use airports are being dismantled at an averaged rate of one airport every several days as neighborhoods encroach upon rural areas, and populated regions petition them out of existence because they are viewed as irrelevant and an annoyance. These small airports provide an untapped transportation resource that will not be able to be replaced in later years.

The question arises, what are the mission requirement differences between PAVs of the future and current GA aircraft that are available in the market today. The future PAV on-demand market will certainly evolve from the current GA market as technologies and capabilities are developed to affect a larger market share. A shift to point-to-point operation models has already occurred with some airlines, though still only at larger airports. As the on-demand market evolves, it is likely to first exist as professionally piloted air-taxi operations from the smaller airports as an intermediate step towards personal on-demand service. As costs

decrease, through such factors as lower acquisition costs and single-pilot operations, more pervasive air-taxi operations of higher utilization vehicles will establish the initial on-demand market. The self-operated on-demand market will follow with the addition of ease of use technologies that permit low cost licensing, and modern certification practices that permit manufacturers to utilize current quality assurance manufacturing processes (instead of the current quality control processes) to achieve both safer and lower cost, high quantity products. The self-operated market will likely evolve into missions that align themselves to the transportation needs of two very different mission classes, rural/regional and intra-urban travel. There will not be a single optimum configuration for these missions, but instead a spread of future potential missions and vehicles that is very broad, just as the automobile market involves from sports cars to SUVs. Therefore it is difficult to select one or two representative missions that can accurately convey the vision of their future capabilities, however representative concepts put the missions into context and provide the ability to understand the vehicle sensitivity to technology investments.

Certain PAV attributes are shared across most missions, as basic capabilities that will be required in the future airspace. This list includes ease of use on par with autos, involving uniform displays and controls, along with ease of pilot licensing; near all weather capability, weather avoidance, and icing awareness systems, with no visibility restriction for landing. A high degree of vehicle automation for systems involving self-diagnosis, pre-flight checklists, emergency procedures, and health monitoring; safety statistics that are on par with commercial airlines, requiring a reduction of ten times in the current GA accident rate²²; good neighbor operations that include noise levels that are similar to motorcycle standards and emissions that are equivalent to current autos; and comfort, interior noise levels, and ride quality that are as good as automobiles.

Rural/Regional Mission Concept Capabilities

Rural and Regional communities are already dependent on General Aviation (GA)² and can provide a start-up PAV market, even with near-term airspace issue constraints. A sufficiently centralized population base doesn't exist for this large portion of the U.S. geographic area to support airline hub and spoke operations with full service, low fares and frequent flights; therefore rural and regional areas are prime candidates for on-demand service. Rural and Regional PAVs will bear many resemblances to GA aircraft since they will share a common infrastructure and a takeoff and landing distance requirement of less than 2500 feet. However, current small GA aircraft cater primarily to

enthusiasts with an emphasis on performance, ignoring or avoiding vehicle characteristics that a typical traveler would require²³. In order for these vehicles to be considered transportation devices, the minimum qualifications of ease, safety, noise, and comfort described previously must be present. In addition the concepts must be economically viable and able to compete with the alternatives of autos or airlines. Advanced concept demonstrations will be required to show that PAVs can be operated by average people, that communities will accept these vehicles, and that they can be produced at costs low enough for a large portion of the public to afford them. In order to establish that at least one approach is present to achieve these goals, conceptual aircraft designs were developed as technology baselines. Due to the high sensitivity of market trip demand to speed, two reference models were developed for moderate (200 mph – Figure 13) and high-speed (300 mph – Figure 14) cruise.

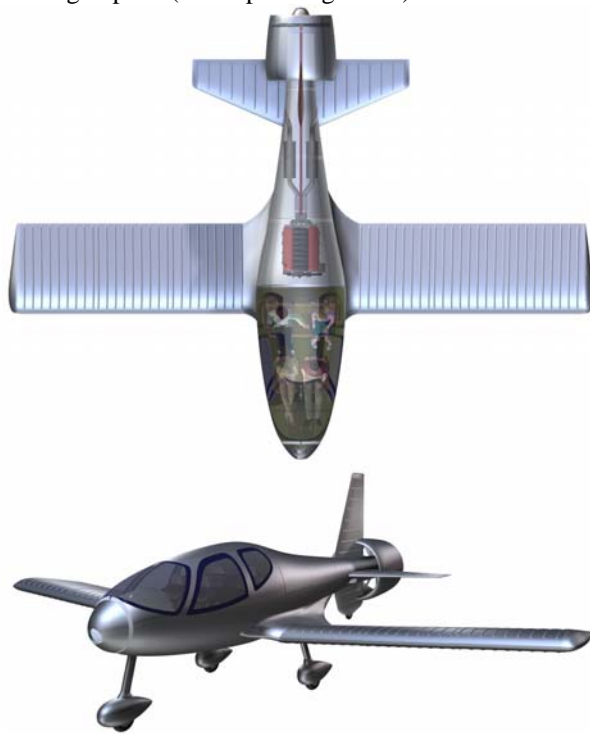

Figure 13. Rural/Regional Next Generation GA Highly Affordable Mission Concept (5 place, non-pressurized, 200 mph cruise, 500 mile range, near all weather, \$75,000 vehicle)

The NASA Langley Tailfan²⁴ is a highly affordable, next generation GA concept (Figures 13 and 14). The design involves a biasing for affordability instead of performance over the complete aircraft system, with advanced quality assurance based certification, and the ability to achieve dramatically reduced community noise and improved operational safety. An all aluminum structure utilizes automotive manufacturing

methods with an untapered, skin-stiffened wing. The structure is radically simplified for manufacturing with a twelve-fold reduction in labor due to the use of a highly symmetric structure with reduced part count, and especially a reduced unique part count. The same parts are used for both sides of the wing simply by flipping the three spars, and using the same four ribs. Identical vertical and horizontal tails utilize the same pressing molds and the same wing skin-stiffened construction. An axis-symmetric tailcone is used with integral frames pressed into each quarter panel, and a fan duct that is made up of four identical sections. Standard rivets or laser welds are used in recessed troughs, under a mylar wing covering for smoothness. This approach is based on many prior successful structural design efforts for small aircraft, with many more proposed methods worth investigating^{25,26,27,28,29}. Structural design of these small aircraft requires different methods and materials than larger aerospace vehicles, as these structures are almost completely designed by minimum gage issues, which is one reason why skin load bearing structures will make more sense than on larger aircraft. More appropriate materials for this application would include less dense, stiffer assemblies, such as the properties exhibited by hollow fiber composites³⁰. Additionally, non-structural items can also benefit from automotive manufacturing processes³¹.



Figure 14. Rural/Regional Next Generation GA High Performance Mission Concept (5 place, pressurized, turbocharged, 300 mph cruise, 500 mile range, near all weather, \$125,000 vehicle)

The Tailfan concept is centered about an automotive V-8 engine (nominally the Corvette LS-1 engine) located close to the center of gravity. The engine is derated to 4000 rpm for reliability and endurance, and directly drives a reduced tip-speed ducted fan. The use of an auto engine involves additional weight compared to aircraft engines, as does the use of a ducted fan compared to the use of a propeller. However, the

combination of the two permits a total propulsion system cost reduction of over 60% while maintaining a reasonable time between overhaul, a specific output that is approximately 2 pounds per horsepower, and an extremely quiet integration^{32,33,34}. This 'fake-jet' balanced V-8 propulsion integration also permits the elimination of noise, vibration and harshness over a big-bore tractor engine installation, great visibility, and the elimination of the propeller that has perceived safety issues to the public. This \$75,000 concept solution is based on a 2000 unit/year production rate, to permit affordability in the transition market between the current low production GA market (1000 units per year across the whole market) and the high volume production of a future PAV market (250,000 units per year). Once a substantial market exists, and large production volumes are present, many of the performance compromises could be eliminated through investment in additional tooling based design and an optimum engine designed specifically for aircraft use.

Currently there are focused efforts on the Tailfan to substantiate the largest design assumptions, including the certification testing of a Corvette LS-1 engine. This FAA endurance testing involves a set standard of 150 hours of harsh tests to demonstrate the reliability and predicted engine life. This particular test is a cornerstone of the Tailfan concept, demonstrating the feasibility of using a Quality Assurance (QA) based product from other industries, instead of the current FAA certification standard of Quality Control (QC). The LS-1 engine passed the endurance test without problem at a 4000 rpm, 280 hp rating which equated to approximately a two pound per horsepower specific output, but at an engine cost of \$5400 instead of \$40,000 for an equivalent power aircraft engine³⁵.

This approach permits both economies of scale and QA production to provide lower cost and more reliable products. Auto manufacturers stopped using QC many years ago, with current practice based on the Toyota pioneered standard of QA based 'Just in Time' manufacturing method. If auto companies were encumbered with government QC based standards, there is little question that automobiles would be much costlier and suffer from lower quality. The intent of the FAA QC regulations are to achieve safer products, however, the current regulations are actually resulting in poorer products that cost much more to produce. The intent of QA based certification is not to bypass the important role of the FAA to insure safety, but to permit certified processes (instead of parts) to enable safer small aircraft products. As long as small aircraft have to use specialty, small production volume, QC based parts, there is little chance of small aircraft being of any significance to the market place or to the

consumer. The new Sport Plane certification standard, which appears to be a QA consensus approach, may be a prototype for this type of certification. If the FAA is unwilling to engage in developing both advanced certification and airspace control, it is very likely that other countries will lead the PAV market. Especially countries with significant rural regions and underdeveloped highway infrastructures, permitting them to bypass ground-based infrastructure¹² just as in the case of the cell phone market today.

Intra-Urban Mission Concept Capabilities

Intra-urban vehicles would further improve point-to-point performance, providing the ability to travel in the air even closer to the final destination and decreasing the average separation distance between small airfields that is currently about 23 miles. In order for this to occur, the vehicles would be required to support smaller airfields (on the order of 500') that could fit within existing urban areas, as well as support airfields in relatively close proximity to major airports as feeders of the hub and spoke system for longer trips. These vehicles are not anticipated to operate in dense urban environments, but as commute or rapid transit in for average stage lengths of 50 to 200 miles of urban areas. To fully realize the potential of this new class of mission vehicles, new infrastructure will need to be developed. But the intent is to keep this infrastructure small enough to permit future airfields in a corner of a mall parking lot, technology campus, hub airport, or neighborhood. The 25 year vision does not encompass takeoff and landing in your driveway (unless you have the space to do so, which is quite possible with the rural expansion that these vehicles empower), but to a community access port that would be within a 1 or 2 miles of your home. It is believed that takeoff and landings will always need to occur in a controlled environment and airspace, albeit small ones.

These Intra-Urban PAVs would take on near-VTOL performance requirements, however, would not necessarily require hover. In fact, there is little to be gained operationally by adding a hover capability for the point-to-point personal travel missions⁶⁰. Specialty missions involving commercial or government services would require hover, which results in far more complex and costly vehicle systems. Clearing a 50' obstacle at 250' and landing on a 100' pad is essentially how helicopters operate today in order to stay out of the dead-man's area of engine failure⁴². Relaxing this requirement to 500 ft field lengths to clear a 50 ft obstacle permits the propulsion system to be sized down much closer that of conventional takeoff vehicles, especially for ducted propeller concepts that benefit from increased static and low-speed thrust. These vehicles will depart and arrive close enough to the final

destination to permit a variety of methods for trip completion, from the equivalent of walking from the parking lot, to being picked up by a shuttle.

An additional Intra-Urban requirement is to encumber the vehicle with the ability to travel on streets in order to provide a complete travel solution within a single dual-mode aerial/readable concept⁴⁰. Many have attempted to design and develop such a vehicle capability^{53,55}, but up to this point in time, it has always involved such dramatic design compromises and penalties as to make the vehicle both a poorly performing car and airplane. The ability for these vehicles to satisfy higher speed DOT highway and crash tests, high-speed gust tolerance while maintaining lane clearance, lightweight suspension and wheels, and failsafe yet simple wing and tail folding systems are significant challenges. As part of the PAVE study, dual-mode concepts were developed at several universities and at NASA Langley. While designer emotions often rule in such concepts as far as the feasibility of these designs, the analysis conducted has not managed to present a compelling case that vehicles burdened with this requirement set could ever meet a practical consumer product.

The Virginia Polytechnic Institute Dual-mode Pegasus concept^{51,52} (Figure 15) used a simple set of pull-out wing extensions that could be stored within the wing root by flipping one wing and stacking them to require the minimum possible depth. But this wing conversion from ground to air mode has to be done by hand, with each panel weighing at least 40 lbs, and requiring control surface assembly connections. This design suffers from the same lack of compactness that most roadable concepts are plagued with, which begs the question whether an individual could tolerate driving the equivalent of a U-haul truck about town.



Figure 15. Dual-mode Virginia Polytechnic Institute Pegasus Concept

While the NASA concept was considerably more compact, it achieved that compactness at the price of a

significant increase in folding complexity, and the use of expensive turbofan engine that were non-optimal for the relatively slow speed cruise that resulted from high body drag. The NASA dual-mode concept (Figure 16) used a combination of single-element telescoping wing and canard panels, along with outer wing panels that fold. The penalties absorbed by this concept included over one thousand pounds of weight growth for a 4-passenger vehicle compared to an equivalent general aviation aircraft. Serious design problems remained unresolved in this concept, including significant body flow blanking of closely coupled vertical surface, though wing endplates were included for added control margin and increased effective span. This concept was neither affordable nor practical, especially when compared to the alternative travel choices. As structure and propulsion technologies advance, this requirement set will become more possible, however, the competing alternative vehicles will also improve from those same technology advancements.



Figure 16. Dual-mode NASA Langley Concept

A more practical dual-mode approach is to require only side-street travel for limited distances in the equivalent of a safe taxi-mode. This capability does not embrace requiring roadable aircraft that are fully compliant with Department of Transportation regulations and safety standards. Instead, these vehicles may choose to meet a minimum set of standards that permit the vehicle to achieve a compact taxi-mode with very few vehicle penalties. By meeting Section 500 vehicle standards⁵⁴, these aircraft could travel at 25 mph on side-streets, as long as they can limit their footprint to a 8.5 ft width and meet some additional relatively simple ground travel requirements. This mode of travel would not use propulsive thrust for movement, but would require the addition of either electric wheel hub motors or a powertrain from the main engine to the wheel. This limited roadway use requirement does not overly

penalize the vehicle, but does involve some weight growth while enabling a door-to-door vehicle solution.

The NASA Langley SpiralDuct concept (Figure 19) was developed as a Gridlock Commuter within the Intra-Urban mission segment. The Gridlock Commuter vehicles are a middle ground that don't quite achieve VTOL point-to-point aerial capability, but do achieve the door-to-door service through the section 500 roadworthiness requirement. The SpiralDuct is based upon the Aerodyne⁵⁶, pioneered by Alexander Lippisch, (Figure 18) and the Custer Channel wing⁵⁸; both of which were able to demonstrate ESTOL performance with few or no moving parts in the high-lift system. Both concepts were tested in NACA wind tunnels during the 1950's with extensive performance and stability and control data available. The Channel Wing is able to achieve a natural thrust vectoring capability that is a function of airspeed, that is, at low speeds the flow is deflected up to 26 degrees while at high speeds the flow is deflected only a small amount⁵⁷. This occurs because the propeller is located in the wing channel and increases the circulation lift on the wing more dramatically at lower freestream velocities because the effective exhaust blowing coefficient is greater. While the Custer implementations of the channel wing were typically dual channels, Hanno-Fischer utilized a single channel (Figure 17) effectively to eliminate asymmetric lift vulnerabilities at low speed operations, which is where most of the mishaps of Channel Wing flight tests occurred. A single duct arrangement also provides the maximum ducted propeller area, and minimum disc-loading, within the confines of a span constraint.

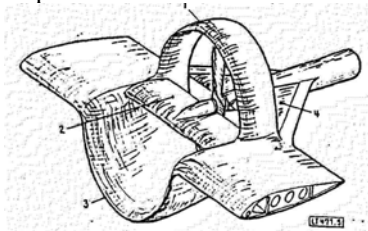

Figure 17. Hanno Fischer Single Duct Version of the Custer Channel Wing



Figure 18. Lippisch Aerodyne Concept in the NASA Ames Wind Tunnel in the 1960's

It is desired that the power requirement is matched between takeoff and the 125 to 150 mph cruise, while limiting the engine size to less than 100 hp. This goal results in minimizing the disc-loading of the propulsion system and maximizing the low-speed thrust, leading to ducted propeller concepts that are also highly desirable for safety of operations. The highly integrated propulsion-aerodynamic coupling enables a 250 ft extreme short takeoff capability with no external high-lift system moving parts, and a C_{Lmax} of 6 to 10, depending on the blowing and trim conditions. Low-speed roll control must be sufficient to handle gust control down to the 30 mph approach speed that is required to meet the takeoff and landing field lengths., which would typically lead to either the implementation of active blowing or over-sizing of control surfaces. However, for this concept integration, roll control can be achieved through the use of all moving outer wing panels in order to maintain a simplistic solution. For a ducted propeller arrangement yaw and pitch control can be enhanced through embedding the control surfaces into the propeller flow. This causes the yaw and pitch control to be coupled to the propulsion system and therefore throttle dependency on effectiveness. For this reason, active controls may be required in order to achieve programmable control surfaces as a function of power and to alleviate the close coupling pitch and yaw trim sensitivity.

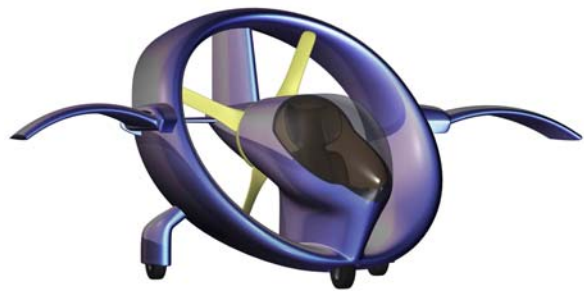
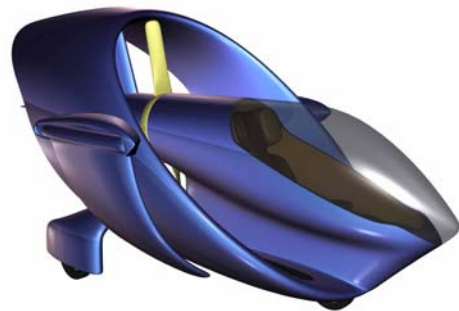

Figure 19. Intra-Urban Gridlock Commuter Concept (2 place, 150 mph, 400 mile range, ESTOL 500' TO, Limited roadway use up to 25 mph speed)

Use of a SpiralDuct arrangement permits approach angles up to 40 degrees angle of attack without tail scrape, which is critical in order to achieve the very high C_{max} demonstrated by the Channel Wing. Due to the propeller flow over the channel, the duct flow has been shown not to stall up to angles of attack of 45 degrees in NACA wind tunnel tests. The SpiralDuct has upper and lower lifting duct surfaces to provide a circular biplane effect, which improves the Oswald efficiency factor by a 1.69 ratio over a monoplane design (though only over the duct span). The outboard panels articulate downward to provide failsafe folding wing structure with the total span for a 6.5 ft duct being 14 ft, but with an effective span of 16 ft. With this span being essentially the largest simple structure that could practically fit on roadways, it is obviously critical to limit the gross vehicle weight so that induced drag doesn't become unreasonable. Therefore this type of vehicle has both limited range and payload, offering at most the ability to handle 1 to 2 passengers (though 72% of all auto travel only involves one person) with a gross weight of less than 1000 pounds.

Other Intra-Urban mission concepts include the Ideal Rotor, Tilt-Nacelle, and PETA V/STOL concepts (Figures 21,23 and 25), that embrace the full point-to-point VTOL capability. The low-speed concept is based on the Hanson Auto-gyro from the 1960's that utilizes a unique, simplified, rigid, auto-trimming rotor hub⁶⁰. The Tilt-Nacelle high-speed concept is based on the Grumman 698 medium speed concept of the 70's and 80's that achieved highly successful full-scale wind tunnel stability and control and hover tests, but was never flown⁶⁴. The Boeing Pulsed Ejector Thrust Augmenter (PETA) is a robust distributed propulsion concept based on prior pulsed engines, but with ejectors for thrust augmentation and muffling. While the Hanson Autogyro has the potential to achieve a low cost approach in the near-term, the more extravagant solutions such as the Tilt-Nacelle have less potential to achieve individual ownership cost targets due to the advanced technology and higher power requirements. Therefore, it is more probable that the higher-speed V/STOL concepts will be high utilization Air-Taxi concept of operation vehicles in order to amortize the higher vehicle acquisition costs.

The Hanson Autogyro advanced concept was explored in a cooperative effort between Georgia Tech Aerospace Design Lab, Tom Hanson, and NASA Langley for the PAVE project (Figures 20 and 21). Hanson had built and tested a prototype ideal rotor system, but had never successfully completed testing or verification of the claims. The rotor is unique in that it has it is bearingless, with no dampers or droop stops, and requires no gyros, stabilizer bars, or powered

control boost. These characteristics establish a simple rotor system that would require significantly less maintenance, and be far less expensive than existing rotor systems. Another favorable characteristic is that it exhibits handling qualities that imply a naturally stable rotor system that would be far easier to fly, with high control power damping and no gust sensitivity. The rotor relies on elastic articulation, with matched stiffness, soft-in-plane, torsionally soft flexure replacing all hinges.

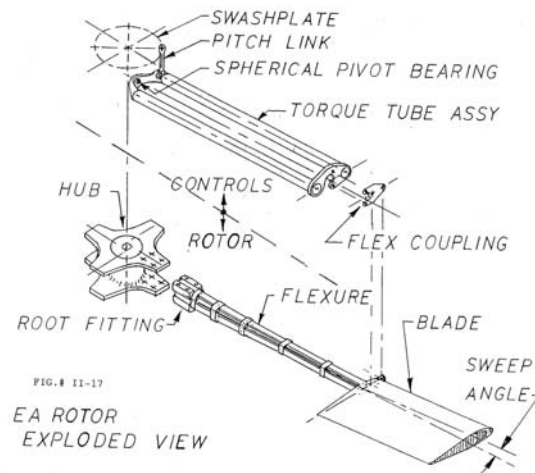

Figure 20. Hanson Ideal Rotor



Figure 21. Georgia Tech/NASA Hanson Autogyro Ultra Mobility Mission Low-Speed VTOL Concept

The auto-trim capability of the Ideal Rotor is achieved through a combination of pitch-flap coupling with slight forward blade sweep and the torsional stiffness of flexure tailored with the forward sweep to provide feathering frequency of about once per revolution (1P), and disturbances counteracted by the 1P feathering produced by the pitch-flap coupling⁶¹. A slight improvement on the order of 10% is also predicted for this concept, with a practical limit at reasonable power loadings of about 150 mph. A jump takeoff is possible through pre-rotation of the rotor, and the ideal rotor concept is equally applicable to a helicopter concept, but with a lower speed of about 125 mph for equivalent power because of the lack of the wing and propeller compounding.

The Tilt-Nacelle concept was developed under a partnership between Mdot Aerospace, Shapery Gyronautics, Georgia Tech Research Institute, and NASA Langley. A tilt-nacelle approach was selected from the many V/STOL concepts that have been attempted over the last 50 years due to the relative simplicity of vehicle control in transition and hover⁶⁵. Typically a Reaction Control System (RCS) is required on V/STOL aircraft to maintain control as airspeed drops below the effectiveness of conventional tail surfaces. The tilt-nacelle uses control vanes in the thrust exhaust to achieve pitch and yaw, with roll control through differential thrust control. One of the major penalties of V/STOL capable aircraft is the large propulsion system required to satisfy the single engine failure without crashing at any point in the flight path. For civil applications with a twin engine arrangement, this results in thrust to weight ratios (T/W) on the order of 2.5 to account for both engine failure, losses due to cross-shafting the engines, turning losses, suckdown, and control power. This propulsion system requirement is about 8 times more than a conventional takeoff aircraft.

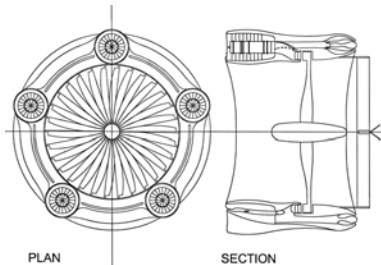

Figure 22. Multi-Gas Generator Fan

A new technology that is being applied to the Tilt-Nacelle is the Multi-Gas Generator Fan (MGGF, Figure 22), which utilizes many, smaller Gas Generators (GG) to turn a tip-driven fan system⁷⁰. With this arrangement, if a single gas generator fails, only 1/5 of the thrust is lost in a five GG setup, to relieve that engine-out penalty. There are many additional reasons to apply this technology, including improved part power efficiency at the high throttle-down ratios in cruise⁷¹. The ability to use lower pressure ratio and lower peak temperature turbines for hover power permits far less expensive turbo-machinery to be used than for the cruise turbine,. Also, with the exhaust products exhausting around the periphery after the fan tip-turbine expansion, there is the potential to drive a circulation control trailing edge for external flow expansion⁷². This is an important consideration since there is a fundamental mismatch between the hover and cruise ducted propulsor sizing, with a large duct desired for hover with low exhaust velocities, and a small duct desired for cruise with high exhaust velocities.

Applying circulation control, or jet coanda blowing over the trailing edge of the duct, the fan flow can be expanded externally to the duct to reduce the fan exhaust velocity⁷³. This permits the fan to be at a higher discloading, while the ground plane experiences lower velocities to avoid ground erosion and debris scattering and damage. Experimental tests were conducted to establish the validity of the flow expansion angle assumptions that are possible using circulation control with promising results in sub-scale tests.



Figure 23. Intra-Urban Ultra Mobility Mission High-Speed VTOL Air-Taxi Concept (5 place, 300 mph cruise, 400 mile range, VTOL)

Another high-speed V/STOL concept developed in a partnership between Boeing and NASA Langley under this project is the Pulsed Ejector Thrust Augmenter (PETA) Concept⁵⁴. While the MGGF is a hybrid of distributed engines driving a central fan, the PETA is a true distributed propulsion concept that exhibits extreme redundancy and robustness⁶⁸. Tens to hundreds of these small-pulsed engines can be utilized to reduce the engine-out penalty to a negligible level, while using a similar exhaust vane control system as the Tilt-Nacelle. One drawback of the concept however is that all prior attempts at pulsed engines have resulted in engines that produced incredible levels of noise, with these devices essentially demonstrating themselves to be the best noise generation devices ever designed. Wrapping an ejector around the pulsed engine to entrain ambient air provides both an augmentation of the thrust, while also providing noise shielding and the ability to apply noise absorbing liners.

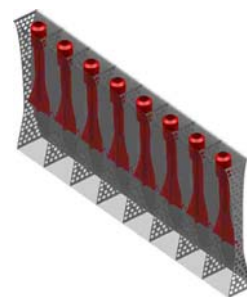

Figure 24. Boeing Pulsed Ejector Thrust Augmenter

Demonstrations have not yet been performed of the PETA concept, and a noise demonstration will certainly be required to address critics. Noise is a critical constraint for all of the V/STOL concepts since the mission goal is to be able to operate in close proximity to businesses, homes, and people. If a strict noise limit is not achieved, these concepts will only be of use to military applications, and even these applications would be limited by violating this important constraint. The amount of noise generated is essentially determined in the conceptual design stage and a product of the discarding and exhaust velocities of the propulsor, and there is very little that can be done to ‘fix’ the noise problem after the fact. Noise cancellation technologies work wonderfully in enclosed environments, such as headphone sets, but are essentially useless in open and uncontrollable free-air environments. For V/STOL concepts to be practical in non airport environments a noise constraint of 90 PNLdb at a 500’ sideline is a reasonable maximum to tolerate, currently a conventional GA aircraft will generate anywhere from 90 to 105 PNLdb.

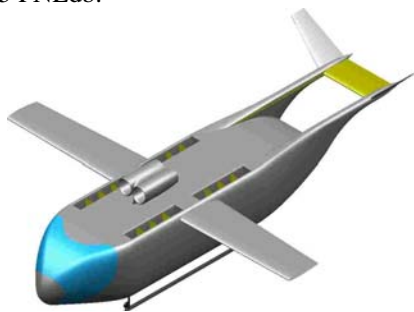

Figure 25. Boeing PETA Ultra Mobility Mission High-Speed VTOL Concept

While these concepts may not appear to make perfect sense in the context of current society and infrastructure, imagine a current production auto being taken back in time 100 years and people being expected to find adequate use for current high-performance autos traveling over mud roads grooved with wagon wheels. Even the long-term concept of operations is not daring to imagine the vision of Star Wars with aerial vehicles completely replacing autos and blotting the sun in densely populated urban areas. Large population centers can only be effectively managed through centralized services, however, with sufficiently dense urbanized areas, centralized services approach an on-demand capability (D.C. metro for instance). Again, the intent of this research is to provide an alternate societal choice than highly concentrated urban areas. The automobile accomplished this at the turn of the 20th century, redistributing the population to less dense suburbs. PAVs would provide an extension of this expansion into the 21st century into further rural areas that are currently underutilized.

TECHNOLOGY CHALLENGES

The technology challenges that exist for a vibrant PAV market have been touched upon throughout this paper. Many of the key hurdles will need not only technology development, but also public demonstration of less quantitative characteristics such as ease of use and community noise acceptability. The required technologies have been grouped into three categories. A near-term set of technologies is required to create a transition growth market that extrapolates from the existing General Aviation market, overcomes a first set of common hurdles across all mission types. These prioritized technologies include ease of use with automatic airspace operations, economically viable concepts with affordable power, advanced certification processes, low community and interior noise, and near all weather capability. The mid-term set of technologies expands upon the accessibility and utility of small aircraft to meet an increased level of everyday use through increased efficiencies and short field performance. These technologies are grouped into propulsion efficiency improvement, increased payload fraction through decreased propulsion system weight, and improved high-lift performance while maintaining simple and robust aerodynamic systems. The far-term set of technologies further increases the short field performance to approach the ultimate goal of point-to-point travel through vertical takeoff and landing operations. These technologies are grouped into environmentally acceptable powered lift capability, lightweight structures, ability to model and analyze unconventional concepts, and the ability to convert alternative energy sources into thrust. Each of these technology groups is discussed below, in order of perceived importance.

Ease of use involves everything from time and cost for proficient training, to interaction with the national airspace system, to operation of the aircraft. Airspace technologies will not be discussed since this is the responsibility of the Small Aircraft Transportation System (SATS) Program^{73,74,75}. SATS is an established program working the airspace issues, while the work outlined in this paper are only the vehicle technologies that would interface with these systems. Obviously there is a considerable cross-over between these efforts, including communications, weather, trip planning and routing, and the degree of pilot control. Industry’s current perception is that the small aircraft market would be considerably larger if this vehicle technology group were able to provide simple and standardized auto-like operation. This logic is based on a comparison of the percentage who can afford to fly, desire to fly, but don’t. However, this is a complex issue involving many real and perceived factors that

interrelate to all of the subsequent technology groups. Ease of use could have a major impact in the improvement of safety since operator error accounts for approximately 65% of accidents alone. One of the key goals of PAV research is to reduce licensing cost to \$1000, with no more than 5 days to complete, versus the current day standard of about \$14,000 and 60 days to complete IFR pilot training.

Simplified user vehicle interfaces include intuitive instrument panel with auto-like simplicity and safe, blunder-resistant controls with the equivalent of a co-pilot on a chip. Pre-flight simplification, terrain and obstacle avoidance, envelope protection, intuitive vehicle health/knowledge systems, synthetic and enhanced vision, velocity vector with haptic control, decision aids, propulsion management systems, weather information and avoidance, autonomous emergency procedures, automatic takeoff/landing, and even incapacitation detection are all part of the ease of use problem to be worked. The AGATE/Raytheon work package made significant strides forward through the autoflight Bonanza effort, which tested automatic flight procedures and the ability of completely inexperienced operators to fly patterns. The proposed efforts would certainly build upon these prior successes and have been defined under the Naturalistic Flight Deck research that is to be conducted in the next fiscal year.

If small aircraft will ever be a significant part of the transportation system, they will need to become much more numerous, and be far more affordable. If achieving affordability is not a primary research goal of this effort, then it can rightly be perceived that this is a government program that is subsidizing rich man's toys. The most expensive subsystem of current aircraft, is the engine system. While aircraft engines are simple and highly optimized for their duty cycles, they are terribly expensive when compared to other categories of power generation. The primary reason for this is due to the small production volumes that exist for these engines of a few thousand units for the total market. Average engine production volume in the auto industry is several hundreds of thousands of units, achieving a cost of \$20 per horsepower for internal combustion (IC) engines versus the cost of over \$100 per horsepower for aircraft IC engines. Turbine based engines are even more expensive, with a 4 times increase over aircraft IC engines. These two types of propulsion systems will continue to be the primary method in the near-term for thrust generation. Electric systems are another alternative for providing relatively simple and robust propulsion systems, however, they require dramatic improvements in energy storage technology prior to achieving competitive power to weight ratios. Other more aggressive propulsion systems are investigated in

the far-term research. The expense of aircraft engines is often attributed to the FAA requirement for quality control, and indeed the current system has not evolved into the more efficient current industry practice of quality assurance. The effort required to create advanced certification procedures goes beyond the engine, into the airframe, displays and software and therefore is a technology area of it's own. The aviation requirement for quality control should not be misunderstood to imply that aircraft engines achieve improved quality over other industries. The reason the auto industry has gone for quality control in the 60's and 70's to quality assurance in the 80's and 90's is because better products results.

In order to achieve the cost reductions required for high-volume small aircraft production, the reduction in cost of isolated sub-systems alone can not make sufficient difference. Economically viable concepts as a complete aircraft system need to be investigated with an objective function of optimizing the entire aircraft for low manufacturing cost. Current studies are demonstrating a high sensitivity between market size and price between the acquisition prices of \$75K to \$100K. Effectively, at these prices (assuming all other consumer barriers have been reduced) small aircraft become very competitive to auto and airline travel, and would be able to capture large portions of their market share. Achieving these types of prices, require cost reductions on the order of 60%, and a complete re-evaluation of how small aircraft are designed and produced. One key to achieving dramatically lower cost is the reduction of labor required to produce an aircraft. Currently small aircraft require 600 to 1200 production man-hours for assembly, leading to very high percentages of labor and labor burden costs. If autos were produced in this fashion, few would be able to afford those either. These factors lead to the need for both improved certification procedures, along with lean design and manufacturing methods that capitalize off the high cost efficiencies of the automobile market. While many will doubt if the FAA would embrace new QA certification procedures, the new light sport plane certification standards appears to be doing just that, with a industry consensus standards approach towards certification^{36,37,38}. Obviously increased production size is critical towards achieving lower costs, but a path towards higher volumes must exist instead of merely the assumption that this leap will take place.

Currently there are very modest noise regulations that are based more on legacy products than community acceptance. Essentially this results in small aircraft that are often times more noisy than large transports. The most modern, advanced small aircraft are also some of the noisiest GA aircraft ever produced⁴⁹. Even if the

engines systems utilized sound suppression systems, propellers are still far too noisy to be tolerated. Current flyover noise ratings are on the order of 70 dbA, though to be considered acceptable to communities, a level more on the order of 55 dbA is required. Ducted propellers offer a method to significantly reduce the acoustical propagation characteristics through a combination of shielding, absorbing liners, and the generation of higher frequency noise that is dissipated more quickly in the atmosphere. Small turbofan engines are also capable of relatively low noise, though only at higher bypass ratios or at lightly loaded conditions⁵⁰. It is not the agenda to mandate new noise regulations for small aircraft, but instead to recognize that new large volumes of small aircraft will need to be acceptable to communities.

SUMMARY

Currently small aircraft lack basic utility and are too expensive, noisy, uncomfortable, difficult to operate, unreliable, and unsafe to be considered for a rational transportation system that would be selected over other competing methods. There are compelling vehicle technology needs that must be resolved prior to the development of a successful market. Yet there is also a pressing need for faster, alternative on-demand mobility systems over the next 25 years, with much of the infrastructure already in place for a Personal Air Vehicle System. An evolutionary path transitioning from current General Aviation operations is necessary, with demonstration of key capabilities and technologies as the market is broadened in scope and utility. The first years of the new PAV S-curve will be shaped by demonstrations in ease of use, quiet propulsion, and safe operations, because these technologies can only be understood the public as they interact and learn to accept this new form of travel. The similarities between the PAV societal transition and the transition to automobile are remarkable. At the turn of the last century city planners grappled with the problem of managing street manure, and looked for more established solutions than a whole new vehicle medium. As the coming years are unraveled³⁰ major new airport

The investment in small aircraft vehicle technologies is one sector of the Aerospace Vehicle Systems Technology Program that supports vehicle technologies across subsonic transports, supersonic aircraft, Uninhabited Aerial Vehicles (UAV), and Runway Independent Aircraft (RIA) sectors. In order to insure that the technologies being developed provide the most 'bang for the buck' each of the candidate technologies are put into context in conceptual vehicles so that their potential benefit can be compared to others. This permits an understanding of how different investment strategies can impact capabilities that are near and dear

to each of us, instead of in terms of obscure technology metrics. The bottom line for PAV technologies is that there is the opportunity to make small aircraft much better than they are today, and to develop an on-demand transportation system that would be much faster and provide more throughput than what we have today. This capability to travel faster, further, anytime, anywhere is a dream that is achievable, and one that could lead us into a new age of mobility.

ACKNOWLEDGEMENTS

Many days of effort were required from researchers at Cessna, Raytheon, Cirrus, Toyota, Williams, Hartzell, Avidyne, DARcorp, the Army, DARPA, NASA Glenn and Langley to bring about different elements of this document. Their intelligence, enthusiasm and fortitude to grapple with the often frustrating and difficult task of requirement and technology definitions is greatly appreciated. This problem statement and initial organization of mission and technology challenges would not have been as valuable without their participation. The wide spectrum of expertise and perspective enabled valuable discussions that were essential in establishing a vision that is beyond the scope of any individual opinion. Establishing a common vision between industry and government is critical to achieve the successful collaborative investment required in order for this future on-demand transportation system to exist.

REFERENCES

1. NASA Aeronautics Blueprint, http://www.aerospace.nasa.gov/aero_blueprint/toc.html
2. Factors Affecting Efforts to Improve Air Service at Small Community Airports, January 2003
3. American Travel Survey, <http://www.bts.gov/programs/ats>
4. SCAG Transportation Demand and Congestion Models, <http://www.scag.ca.gov>
5. Los Angeles Regional Transportation Plan, Southern California Association of Governments, <http://www.scag.ca.gov/rtp/mainrtp.html>.
6. Atlanta 2025 Regional Transportation Plan, <http://www.atlantaregional.com/transportation/air/2025RTP.html>
7. The Machine that Changed the World: The Story of Lean Production, Womack, J.P., Harper Perennial, 1991, 323 pages.
8. Early Days of Automobiles, Janeway, E., Random Library, 1956, 192 pages.
9. Wheels for the World: Henry Ford, His Company and a Century of Progress 1903-

- 2003, Brinkley, D., Viking Press, 2003, 858 pages.
10. America on Wheels – The First 100 Years, Coffey, F., 1996.
 11. Modeling Global Mobility, Schaefer, Transportation 2050, <http://scitech.dot.gov/policy/vision2050/agenda.html>
 12. Urban Mobility in the Developing World, Gakenheimer, R., Dept Urban Studies and Planning, MIT, TRP 671-689, 1999.
 13. Personal Air Vehicle Tool and Modeling Final Report, DeLaurentis, D. et al, Georgia Tech Aerospace Design Lab, Oct 2002.
 14. System of Systems Modeling for Personal Air Vehicles, DeLaurentis, D. et al, Georgia Tech Aerospace Design Lab, Oct 2002, AIAA Paper.
 15. Analysis of Small Aircraft as a Transportation System, Dollyhigh, S.M., NASA CR 2002-211927.
 16. Business Airplanes, Business & Commercial Aviation, May 2001, p 58-118.
 17. SATS Overview, Small Aircraft Transportation Office, NASA, http://sats.larc.nasa.gov/overview_sats.html, June 2002.
 18. General Aviation Manufacturers 2002 Shipments, <http://www.gama.aero/dloads/2002ShipmentReport.pdf>.
 19. Airlife's General Aviation, Simpson, R.W. , 1995.
 20. The Innovator's Dilemma, Christensen, C.M., Harper Business Press, 1997, 252 pages.
 21. Economic Policy Institute, <http://www.epinet.org>
 22. Aviation Safety Statistical Handbook, U.S. Department of Transportation Federal Aviation Administration, 1999 Annual Report.
 23. The Typical General Aviation Aircraft, Turnball, A., FDC/NYMA Inc Langley Research Center, NASA CR-1999-209550, Sept 1999.
 24. Highly Affordable Personal Air Vehicles, Moore, M. D. and Hahn, A.S., Contact Magazine, July 2002.
 25. Potential Structural Materials and Design Concepts for Light Aircraft, San Diego Aircraft Engineering Inc, NASA CR-1285, March 1969.
 26. Aircraft Designers Data Book, Neville, L.E., McGraw Hill, 1950.
 27. Design Analysis of Republic SeaBee, Stone, I., Aviation Magazine, May 1946.
 28. Design for Low Cost Production, Boyajian, A.Z., Aircraft Production Magazine, Oct 1946.
 29. Design Considerations for Inexpensive Aircraft, Marchev, A., Industrial Aviation Magazine, Dec 1945.
 30. Optimization of Hollow Glass Fibers and Their Composites, Huckler, M. and Bond, I., Univ. of Bristols, Advanced Composite Letters, Vol 8, No 4, Sept 1999.
 31. Automotive Approaches for General Aviation Aircraft, Greico, D., Munro and Associates, The Advanced General Aviation Transport Experiments Project, Work Package 7.0, March 2002.
 32. Shrouded Propellers – A Comprehensive Performance Study, Blick, D.M. et al, Hamilton Standard, A68-44951, 1968.
 33. Advanced General Aviation Propeller Study, Worobel, R., Hamilton Standard, NASA CR 114289, Apr 1971.
 34. Q-Fans for General Aviation Aircraft, Worobel, R. and Mayo, M., Hamilton Standard, NASA CR 114665, Dec 1973.
 35. Automotive Engines for NASA PAVE Project, Iannetti, F., Design Ideas Inc, June 19, 2003.
 36. Approved for Flight, Sedgwick, S., ASTM Standardization News, Dec 2002, p 31-33.
 37. Light Sport Aircraft Standards, Martin, D., Kitplanes, July 2003, p 2.
 38. Roll Your Own Kit-Built Airplane, Light Plane Maintenance, June 2003, p 6-10.
 39. The Personal Aircraft – Status and Issues, Anders, S. et al, NASA Langley, NASA TM 109174, Dec 1994.
 40. Personal Air Vehicle and Flying Jeep Concepts – A Commentary of Promising Approaches, Hall, D., Cal Poly San Luis, July 24, 2001, 90 pages.
 41. Airpark Living, Larsen, Ousterhout and Berthe, Kitplanes, June 2003, p 16-29.
 42. Category A One Engine Inoperative Procedures and Pilot Aids for Multi-Engine Civil Rotorcraft, Iseler, L. et al, NASA Ames, SAE Paper 965616.
 43. Vertical Flight in an Obstacle-Rich Environment, Sawyer, B., SAIC, SAE Paper 965614.
 44. Potential Impacts of Advanced Aerodynamic Technology on Air Transportation System Productivity, Bushnell, D.M., Langley Research Center, NASA TM 109154, Sept 1994.
 45. Overview of ACSYNT for Light Aircraft Design, Gelhausen, P.A. and Moore, M.D., SAE Paper 951159.

46. Design for Flying, Thurston, D., Tab Books, McGraw Hill, 1995, 308 pages.
47. Technical Thresholds for Revitalizing General Aviation, Kraus, E.F., Cessna Aircraft, A88-14275.
48. Conceptual Design of Single Turbofan Engine Powered Light Aircraft, Cessna Aircraft, NASA CR-151973, May 1977.
49. Estimated Airplane Noise Levels in A-Weighted Decibels, Burluson, C.E., FAA Advisory Circular 36-3H, April 25, 2002,
50. Noise Certifications for FJX-2 Powered Aircraft Using Analytic Methods, Berton, J.J., NASA Glenn Systems Analysis White Paper, 2001,
51. An Investigation of CTOL Dual-Mode PAVE Concepts, Marchman, J. et al, Virginia Tech, Virginia Tech AOE Report 276, Jan 2002.
52. The Investigation of an Inboard-Winglet Application to a Roadable Aircraft, Intaratep, N., Virginia Tech Master's Thesis, May 31, 2002.
53. Concept Study of the Converticar Roadable Helicopter, Head, R., McDonnell Douglas Helicopter Systems, MDHS Report NAS-20342-001, July 1997.
54. Dual-Mode Air Transportation System (DARTS) Final Report, Cummings, D.B. and Hoisington, Z., Boeing Phantom Works, Long Beach CA, Feb 14, 2002.
55. Private Air Transportation with Advanced Flying Automobiles and Roadable Aircraft and Impact on Intercity and Metropolitan Infrastructures, Sahr, B. et al, SAE Paper 985536.
56. A Large-Scale Wind-Tunnel Investigation of a Wingless Vertical Takeoff and Landing Aircraft, Koenig, D.G et al, Ames Research Center, TN D-1335, Feb 1963.
57. Large-Scale Wind-Tunnel Tests of a Wingless Vertical Takeoff and Landing Aircraft, Koenig, D.G. et al, NASA Langley Research Center, NASA D-326, Oct 1960.
58. Langley Full-Scale Tunnel Tests of the Custer Channel Wing Airplane, Pasamanick, J., Langley Aeronautical Lab, RM L53A09, April 7, 1953.
59. Super STOL – A Proposal for General Aviation, Hanson, T., Hanson Consulting Inc, May 1969.
60. The Auto-Trim Rotor Stability System, Hanson, T., Tom Hanson Consulting, Newhall, CA.
61. Wind Tunnel Tests of an Optimized Matched Stiffness Rigid Rotor, Hanson, T., Lockheed California Company, Lockheed Report No 17790, July 1964.
62. A Perspective on the First Century of Vertical Flight, Hirschberg, M., ANSER Inc, AIAA Paper 1999-01-5584.
63. Review of Powered-Lift Technology, Johnson, J. et al, Eagle Consulting, Oct 24, 1991.
64. Hover and Transition Flight Performance of a Twin Tilt Nacelle V/STOL Configuration, Pierera, M., AIAA Paper 83-1824, July 1983.
65. Aerodynamic Characteristics of a Large-Scale Twin Tilt-Nacelle V/STOL Model, Falarski, M.D. et al, AIAA Paper 81-0150, Jan 1981.
66. Vertical Takeoff and Landing Aircraft, Campbell, J.P., The MacMillan Company, New York, 202 pages.
67. The Aerodynamics of the Unconventional Air Vehicles of A. Lippisch, Borst, H., Henry Borst and Associates, 1980.
68. Brief Overview of Distributed Propulsion Concepts and the Utilization of Small, Mini, and Micro Engines, NASA Glenn Research Center Systems Analysis Branch White Paper, April 13, 2001.
69. The Last Frontier – VTOL, Kress, R., Flight Journal, June 2003, p 46-52.
70. Preliminary Performance Study of a Multiple-Gas Generator-Driven Lift Fan for V/STOL Aircraft, Dodge, J.L. et al, MDOT Aerospace, Phoenix, AZ, October 15, 2001.
71. Multi-Gas-Generator-Driven Fan Engine with Circulation Control Nacelle, Mdot Aerospace, Revolutionary Aero-Propulsive Concepts Final Report, March 31, 2003.
72. Experimental Investigation of a Circulation Controlled Shrouded Propeller, Walters, R.E., West Virginia Univ, Office of Naval Research, Feb 1974.
73. Flow Control Research at NASA Langley in Support of High Lift Augmentation, Sellers, W.L, Jones, G.S., and Moore, M.D., AIAA Paper 2002-6006, Nov 2002.
74. Freedom of the Skies, Fallows, J., The Atlantic Monthly, June 2001.
75. The Transition Towards Free Flight: A Human Factors Evaluation of Mixed Equipage, Integrated Air-Ground, Free Flight ATM Scenarios, Ruigrok, R.C et al, National Aerospace Laboratory NRL, SAE Paper 1999-01-5564.
76. Free Flight: From Airline Hell to a New Age of Travel, Fallows, J., Public Affairs Press, 2001, 253 pages.